

Photoelectric Sensor with Built-in Amplifier with New Connector Options

E3Z

Compact Sensor Offers Long Sensing Distance and Superior Noise-Immunity

- Photo-IC provides long sensing distance: 15 m and 10 m for through-beam, 4 m for retroreflective, and 1 m for diffuse.
- Integrated Photo-IC improves noise immunity to interference from inverters and other inductive loads.
- New injection molding technology assures IP67 rating to withstand water and dust.
- Switch-selectable, Light-ON/Dark-ON operation.
- M8 connector-ready and 2 m, pre-wired models.
- NPN or PNP output models available.



Ordering Information

■ Sensors

Stock Note: Shaded models are normally stocked.

Sensing method	Light source	Appearance	Connection method	Sensing distance	Model	
					NPN output	PNP output
Through-beam	IR/RED		Pre-wired	15 m (IR) 10 m (RED) (See Note 1.)	E3Z-T61(A)	E3Z-T81(A)
			Connector		E3Z-T66(A)	E3Z-T86(A)
			Pigtail 3 pin (M8)		E3Z-T61(A)-M5J	E3Z-T81(A)-M5J
			Pigtail 4 pin (M8)		E3Z-T61(A)-M3J	E3Z-T81(A)-M3J
			Pigtail 4 pin (M12)		E3Z-T61(A)-M1J	E3Z-T81(A)-M1J
Polarized retroreflective	RED	 (See Note 2.)	Pre-wired	100 mm to 4 m 100 mm to 3 m (See Note 3.)	E3Z-R61	E3Z-R81
			Connector		E3Z-R66	E3Z-R86
			Pigtail 3 pin (M8)		E3Z-R61-M5J	E3Z-R81-M5J
			Pigtail 4 pin (M8)		E3Z-R61-M3J	E3Z-R81-M3J
			Pigtail 4 pin (M12)		E3Z-R61-M1J	E3Z-R81-M1J
Diffuse reflective	IR		Pre-wired	5 to 100 mm (wide view)	E3Z-D61	E3Z-D81
			Connector		E3Z-D66	E3Z-D86
			Pigtail 3 pin (M8)		E3Z-D61-M5J	E3Z-D81-M5J
			Pigtail 4 pin (M8)		E3Z-D61-M3J	E3Z-D81-M3J
			Pigtail 4 pin (M12)		E3Z-D61-M1J	E3Z-D81-M1J
			Pre-wired	1 m	E3Z-D62	E3Z-D82
			Connector		E3Z-D67	E3Z-D87
			Pigtail 3 pin (M8)		E3Z-D62-M5J	E3Z-D82-M5J
			Pigtail 4 pin (M8)		E3Z-D62-M3J	E3Z-D82-M3J
			Pigtail 4 pin (M12)		E3Z-D62-M1J	E3Z-D82-M1J

Note: 1. Model numbers that end with (A) are red LED versions.

2. The Reflector is sold separately. Select the Reflector model most suited to the application.

3. Sensing distance can be extended to 4 meters when the E39-R1S reflector is used. The sensing distance is 3 meters when the E39-R1 reflector is used.

■ **Accessories (order separately)**

Stock Note: Shaded models are normally stocked.

Slit for Through-beam Models (E3Z-T□□)

Order a slit for each emitter and receiver.

Slit width	Sensing distance (typical)	Minimum sensing object (typical)	Model
0.5 mm dia.	50 mm	0.5 mm dia.	E39-S65A
1 mm dia.	200 mm	1 mm dia.	E39-S65B
2 mm dia.	800 mm	2 mm dia.	E39-S65C
0.5 × 10 mm	1 m	0.7 mm dia.	E39-S65D
1 × 10 mm	2.2 m	1.2 mm dia.	E39-S65E
2 × 10 mm	5 m	2.4 mm dia.	E39-S65F

■ **Reflectors for Retroreflective Models**

Stock Note: Shaded models are normally stocked.

Name	Sensing distance (typical)	Model
Reflector	100 mm to 3 m	E39-R1
	100 mm to 4 m	E39-R1S
	100 mm to 5 m	E39-R2
	100 mm to 2.5 m	E39-R9
	100 mm to 3.5 m	E39-R10
Miniature Reflector	50 mm to 1.5 m	E39-R3
Tape Reflector	150 mm to 700 mm	E39-RS1
	150 mm to 1.1 m	E39-RS2
	150 mm to 1.4 m	E39-RS3

Note: The actual sensing distance may be reduced to approximately 70% of the typical sensing distance when using a Reflector other than the E39-R1 or the E39-R1S.

■ Mounting Brackets

Stock Note: Shaded models are normally stocked.

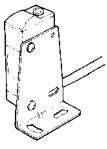
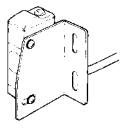
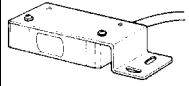
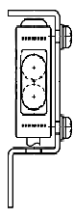
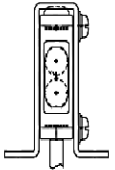
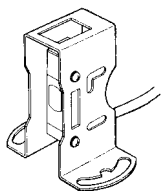
Appearance	Description	Model
	L-bracket, horizontal	E39-L104
	L-bracket, vertical	E39-L44
	Open top, 20° angle adjustability	E39-L43
	Protected top 5° angle adjustability	E39-L144
	Compact vertical protective cover bracket	E39-L142
	Vertical protective cover bracket	E39-L98

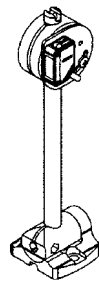
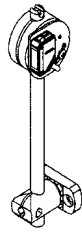
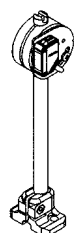
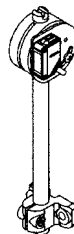
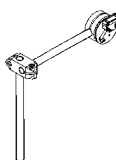
Appearance	Description	Model
	Adjustable height and angle bracket for sensors; horizontal mounting rotates every 45 degrees Mounted to the aluminum frame rails of conveyors, easily adjustable	E39-L93FH
	Adjustable height and angle bracket for sensors; vertical mounting rotates every 45 degrees	E39-L93FV
	Adjustable height and angle bracket for sensors; fixed horizontal base mounting	E39-L93H
	Adjustable height and angle bracket for sensors; fixed vertical base mounting	E39-L93V
	Adjustable height and angle bracket for sensors; free range of X and Y axis positioning; no base included for vertical post	E39-L93XY

Note: If a through-beam model is used, order two Mounting Brackets — one for the emitter and one for the receiver.

■ M8 CONNECTORS

Appearance	Cable type		Model
Straight	2 m (6.56 ft)	Four-wire type	XS3F-M421-402-A
	5 m (16.40 ft)		XS3F-M421-405-A
Right angle	2 m (6.56 ft)		XS3F-M422-402-A
	5 m (16.40 ft)		XS3F-M422-405-A
Straight	2 m (6.56 ft)	Three-wire type	Y96E-M833SD2
	5 m (16.40 ft)		Y96E-M833SD5
Right angle	2 m (6.56 ft)		Y96E-M833RD2
	5 m (16.40 ft)		Y96E-M833RD5

■ M12 CONNECTORS

Appearance	Cable type		Model
Straight	2 m (6.56 ft)	Four-wire type	Y96E-44SD2
	5 m (16.40 ft)		Y96E-44SD5
Right angle	2 m (6.56 ft)		Y96E-44RD2
	5 m (16.40 ft)		Y96E-44RD5

Specifications

Item	Sensing method		Through-beam	Polarized retroreflective	Diffuse reflective	
		NPN output		E3Z-T61/T66 (A) (Note 3)	E3Z-R61/R66	E3Z-D61/D66
	PNP output		E3Z-T81/T86 (A) (Note 3)	E3Z-R81/R86	E3Z-D81/D86	E3Z-D82/D87
Sensing distance			15 m 10 m (A) (Note 3)	100 mm (4 m Note 1) (when using E39-R1S) 100 mm (3 m Note 2) (when using E39-R1)	White paper (100 × 100 mm): 100 mm	White paper (300 × 300 mm): 1 m
Standard sensing object			Opaque: 12 mm (dia. min.)	Opaque: 75 mm (dia. min.)	---	---
Hysteresis			---	---	20% max. of setting distance	
Directional angle			Both emitter and re- ceiver: 3 to 15°	2 to 10°	---	
Light source (wave length)			Infrared LED (870 nm)	Red LED (660 nm)	Infrared LED (860 nm)	
Power supply voltage			12 to 24 VDC ±10% including 10% (p-p) max. ripple			
Current consumption			Emitter: 15 mA Receiver: 20 mA	30 mA max.		
Control output			100 mA max. at 26.4 VDC, open collector output (residual voltage: 2 V max.) < 10 mA (residual voltage: 1 V max.) L-ON/D-ON, switch selectable			
Circuit protection			Load short-circuit, re- versed power supply protection, and output reverse protection	Reversed power supply connection, output short-circuit, and mutual interference protection, and output reverse protection		
Response time			1 ms max.			
Sensitivity adjustment			One-turn potentiometer			
Ambient illumination (receiver side)	Incandescent lamp	3,000 ℓ max.				
	Sunlight	10,000 ℓ max.				
Ambient temperature	Operating	-25°C to 55°C (-13°F to 131°F)				
	Storage	-40°C to 70°C (-40°F to 158°F) with no icing or condensation				
Ambient humidity	Operating	35% to 85%				
	Storage	35% to 95% with no condensation				
Insulation resistance		20 MΩ min. at 500 VDC				
Dielectric strength		1,000 VAC, 50/60 Hz for 1 min				
Vibration resistance		10 to 55 Hz, 1.5-mm double amplitude or 300 m/s ² for 2 hours each in X, Y, and Z axes				
Shock resistance	Destruction	500 m/s ² 3 times each in X, Y, and Z axes				
Enclosure rating		IP67 (IEC60529) 1200 PSI Washdown (NEMA ICS5, ANNEX F)				
Approvals		CE				
Connection method		2 m cable or M8 connector				
Indicator		Operation indicator (orange) Stability indicator (green) Emitter has power indicator (orange) only				
Weight (packed state)	Pre-wired cable (2 m)	Approx. 120 g (4.2 oz)	Approx. 65 g (2.3 oz)			
	Connector	Approx. 30 g (1.1 oz)	Approx. 20 g (0.7 oz)			
Material		Case: PBT (polybutylene terephthalate); Lens: Denatured polyallylate				
Accessories		Instruction manual (Order Reflector and Mounting Bracket separately.)				

Note: 1. Sensing distance can be extended up to 4 meters when the E39-R1S reflector is used.

2. Sensing distance can be extended up to 3 meters when the E39-R1 reflector is used.

3. Sensing distance is 10 meters when using the (A) versions (visible red LED, 660 nm).

Nomenclature

Through-beam Models
E3Z-T6□ Receiver

Retroreflective Models
E3Z-R6□

Diffuse-reflective Models
E3Z-D6□

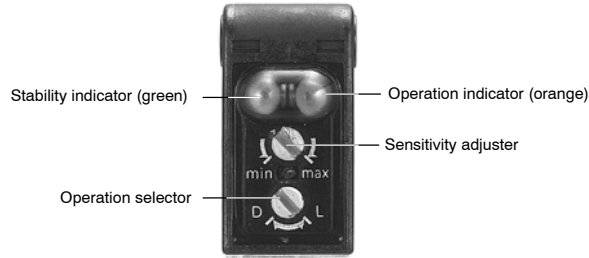

Operation

Output Circuits

Model	E3Z-T61/-T66/-R61/-R66/-D61/-D66/-D62/-D67	
NPN output	Through-beam receiver Retroreflective model Diffuse reflective model	Through-beam emitter
Model	E3Z-T81/-T86/-R86/-D81/-D86/-D82/-D87	
PNP output	Through-beam receiver Retroreflective model Diffuse reflective model	Through-beam emitter
Connector pin arrangement	<p>Pin 2 is open.</p>	<p>Pins 2, 4 are open.</p>

Timing Charts

Light-ON (L-ON) Operation

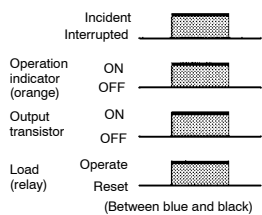

Dark-ON (D-ON) Operation

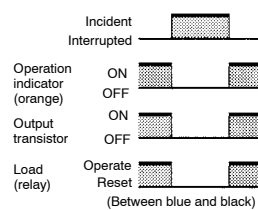

■ M8 Connector PIN-OUT (4-Pin)

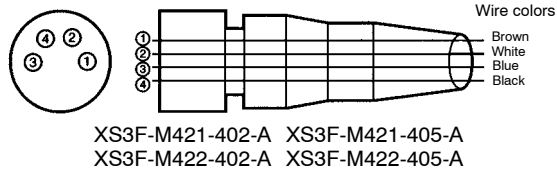

(3-Pin)

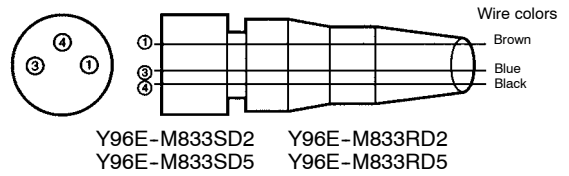

Classification	Wire color	Connector pin No.	Description
DC	Brown	1	Power supply (+V)
	White	2	Pin 2 is not used.
	Blue	3	Power supply (0 V)
	Black	4	Output

Note: The through-beam emitter does not use pins 2 and 4.

■ M12 Connector PIN-OUT (4-Pin)

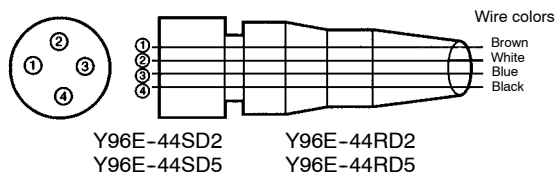

Classification	Wire color	Connector pin No.	Description
DC	Brown	1	Power supply (+V)
	White	2	Pin 2 is not used.
	Blue	3	Power supply (0 V)
	Black	4	Output

Note: The through-beam emitter does not use pins 2 and 4.

Engineering Data

Parallel Operating Range (typical)

Through-beam Models
E3Z-T□1 (T□6)

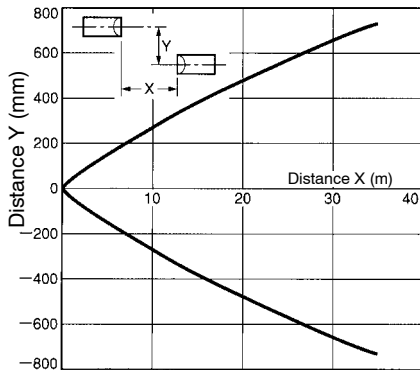

Through-beam Models
E3Z-T□1 (T□6) and Slit

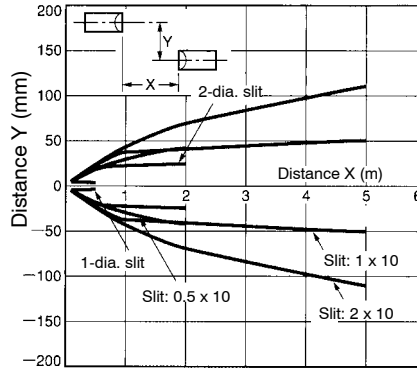

Retroreflective Models
E3Z-R□1 (R□6) and Reflector

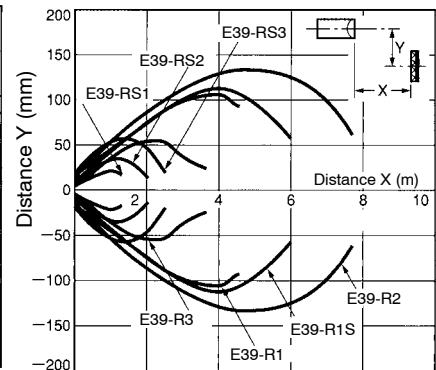

Parallel Operating Range (Typical)
E3Z-T□A

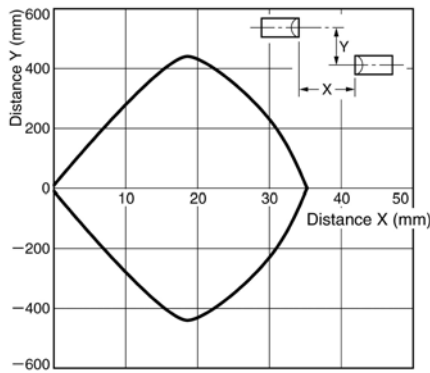

Receiver Output vs. Distance (Typical)
E3Z-T□A

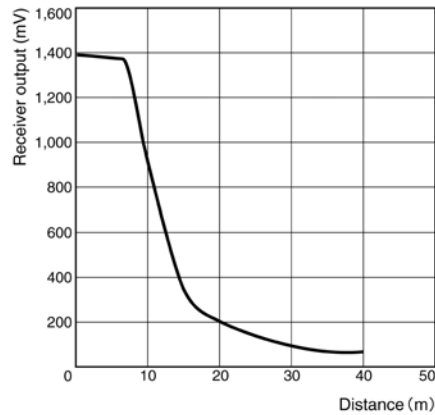

Operating Range (typical)

Diffuse Reflective Models
E3Z-D□1 (D□6)

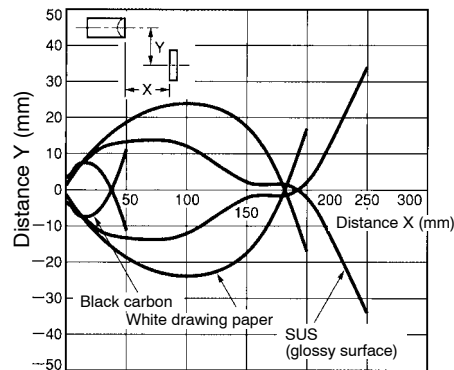

Diffuse Reflective Models
E3Z-D□2 (D□7)

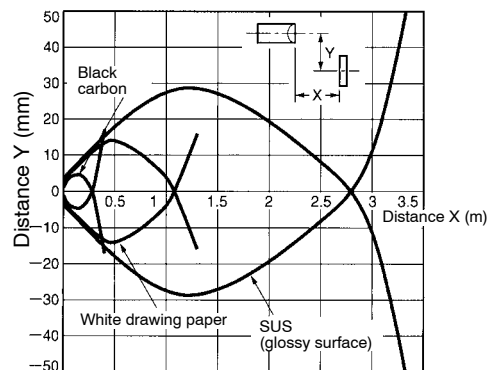

■ Excess Gain Ratio vs. Distance (typical)

Through-beam Models
E3Z-T□1 (T□6)

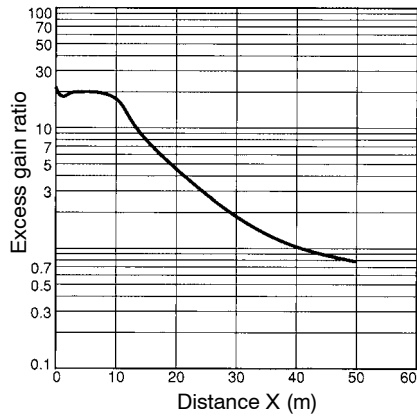

Retroreflective Models
E3Z-R□1 (R□6) and Reflector

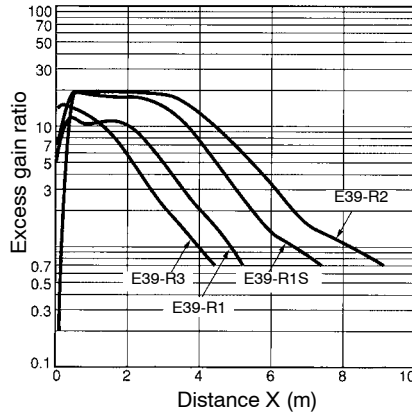

Diffuse Reflective Models
E3Z-D□1 (D□6)

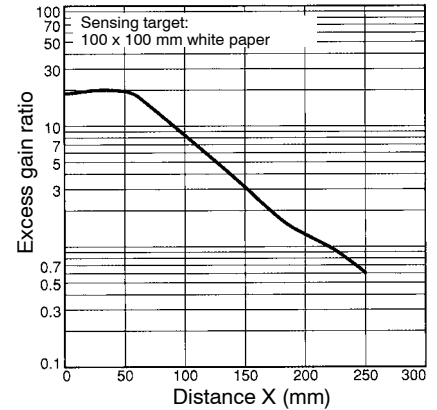

Diffuse Reflective Model
E3Z-D□2 (D□7)

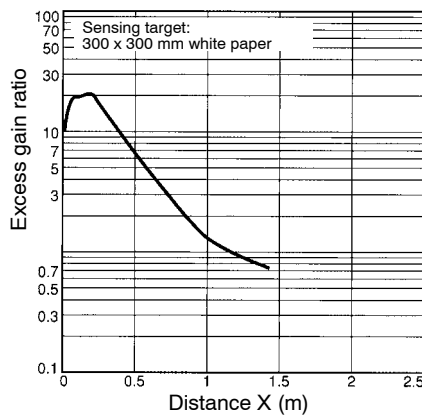

■ Sensing Target Size vs. Sensing Distance (typical)

Diffuse Reflective Models
E3Z-D□1 (D□6)

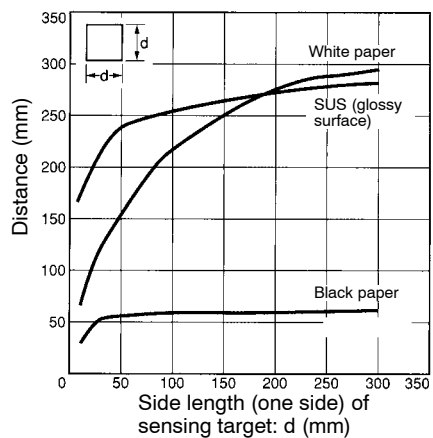

Diffuse Reflective Models
E3Z-D□2 (D□7)

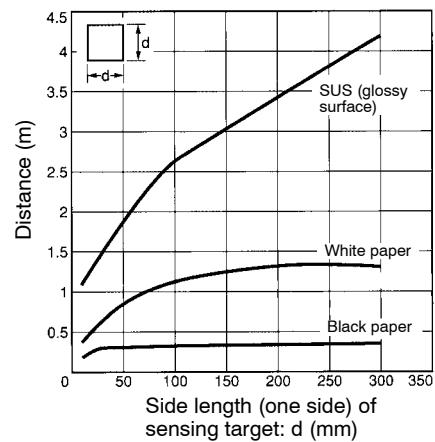

Dimensions

Unit: mm (inch)

Sensors

Through-beam (Pre-wired Models)

E3Z-T61
E3Z-T81

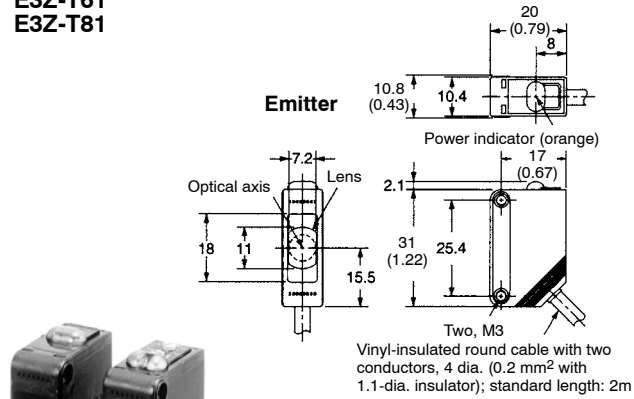

Through-beam (Connector Models)

E3Z-T66
E3Z-T86

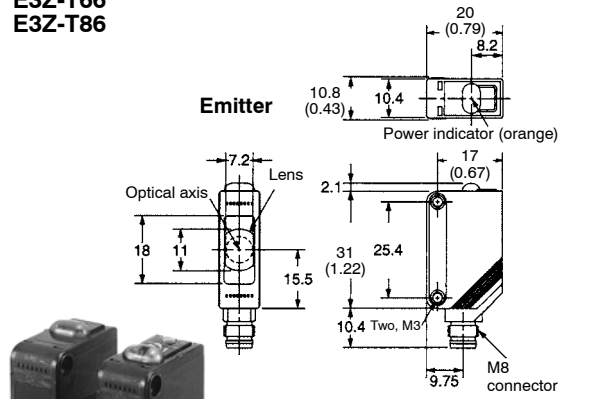

Retroreflective Models (Pre-wired Models)

E3Z-R61
E3Z-R81

Diffuse Reflective Models (Pre-wired Models)

E3Z-D61
E3Z-D62
E3Z-D81
E3Z-D82

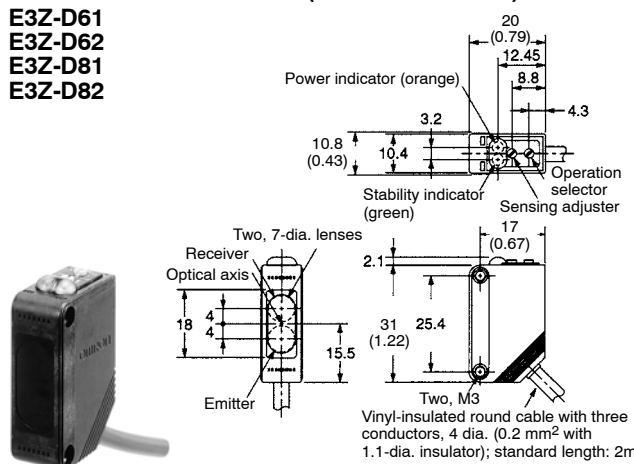

Retroreflective Models (Connector Models)

E3Z-R66
E3Z-R86

Diffuse Reflective Models (Connector Models)

E3Z-D66
E3Z-D67
E3Z-D86
E3Z-D87

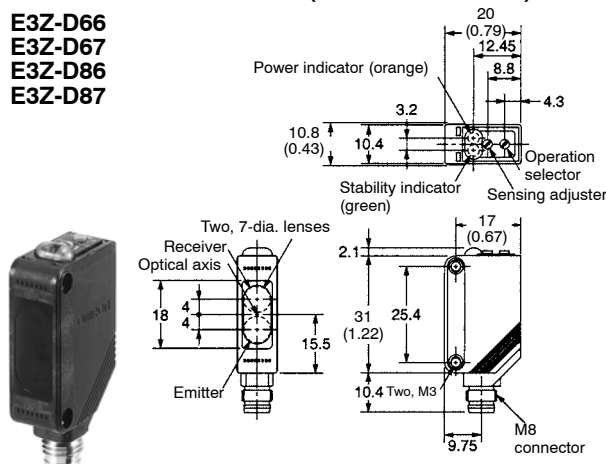

Note: Length of pigtailed: 0.3 m

Unit: mm (inch)

■ Slits

E39-S65A
E39-S65B
E39-S65C

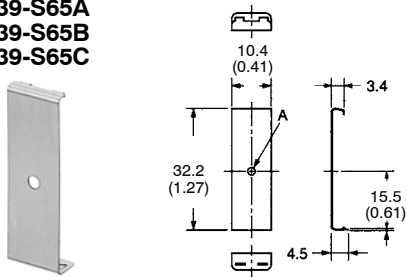

Model	Side A	Material
E39-S65A	0.5 dia.	SUS301 stainless steel
E39-S65B	1.0 dia.	
E39-S65C	2.0 dia.	

E39-S65D
E39-S65E
E39-S65F

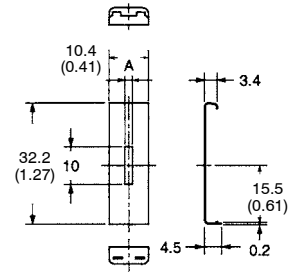

Model	Side A	Material
E39-S65D	0.5	SUS301 stainless steel
E39-S65E	1.0	
E39-S65F	2.0	

■ Reflectors

E39-R1
E39-R1S

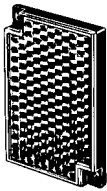

Material
Surface: Acrylic resin
Backside: ABS resin

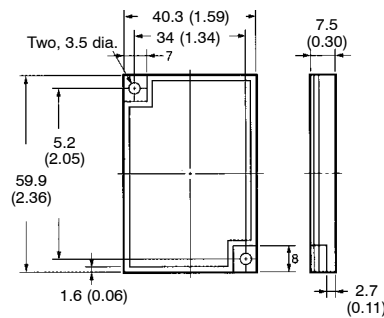

E39-R2

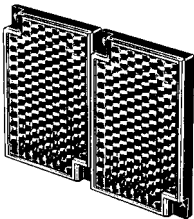

Material
Surface: Acrylic resin
Backside: ABS resin

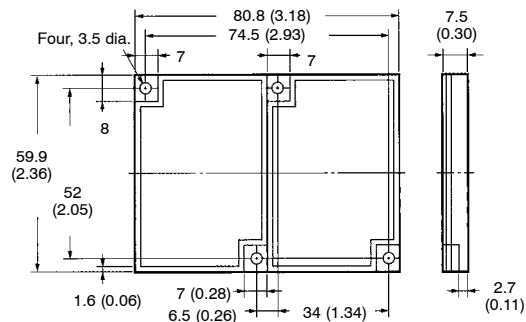

E39-R9



Material
Reflecting surface: Acrylic resin
Back: ABS resin

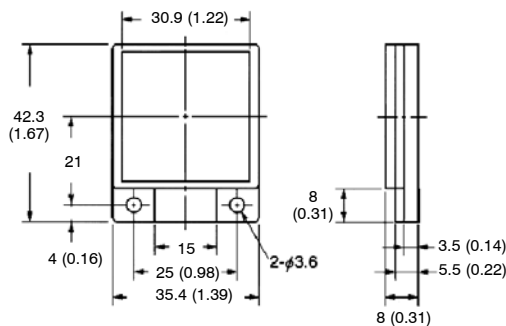

E39-R10

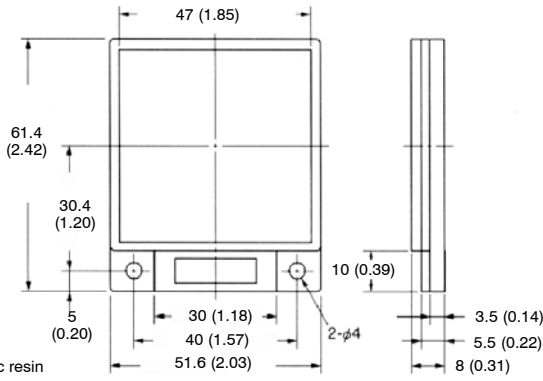

Material
Reflecting surface: Acrylic resin
Back: ABS resin

■ **Miniature Reflector**

E39-R3



Material
Surface: Acrylic resin
Backside: ABS resin

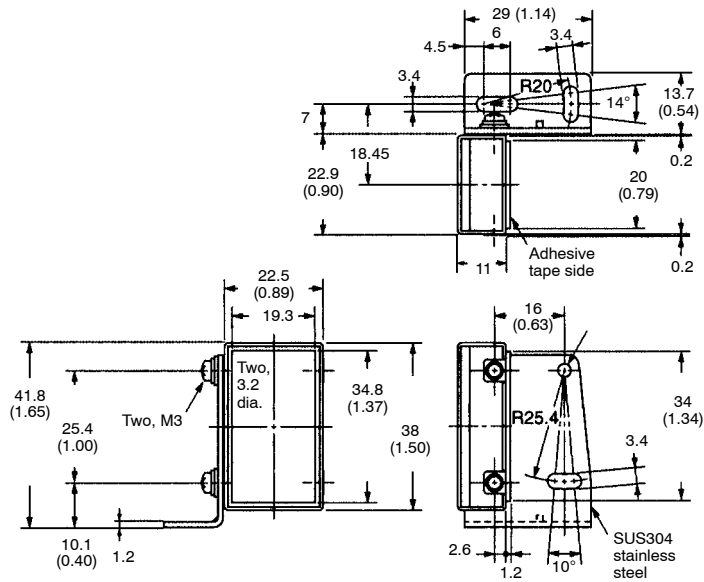

■ **Tape Reflectors**

E39-RS1



Material:
Acrylic resin

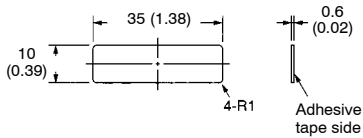

E39-RS3

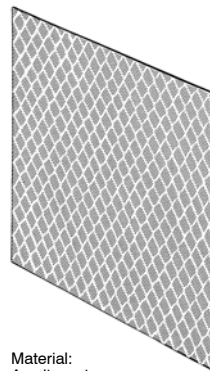

Material:
Acrylic resin

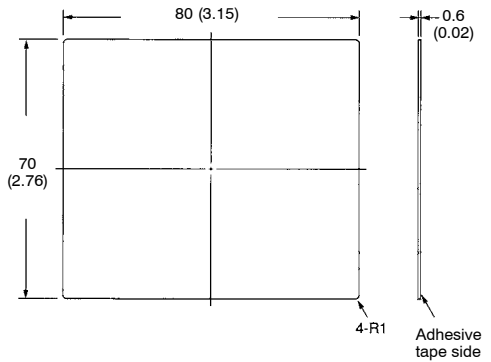

E39-RS2

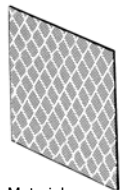

Material:
Acrylic resin

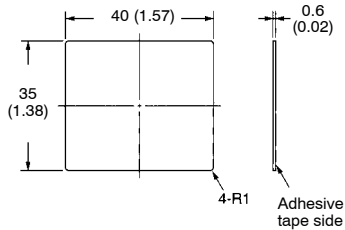

Unit: mm (inch)

■ Mounting Brackets

E39-L104

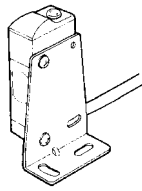

Material:
SUS304
stainless steel

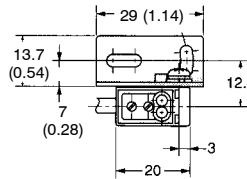
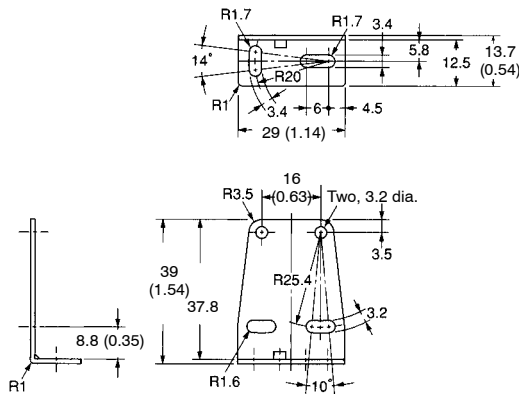

With Mounting Bracket
(E3Z-D62)

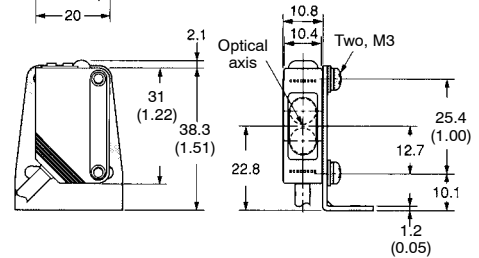

E39-L43

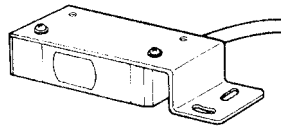

Material:
SUS304
stainless steel

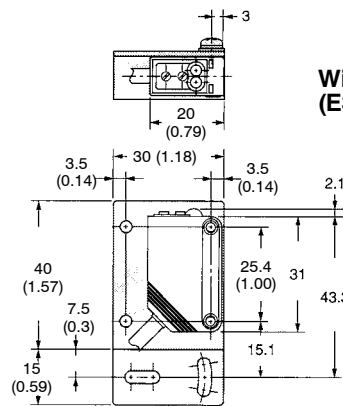
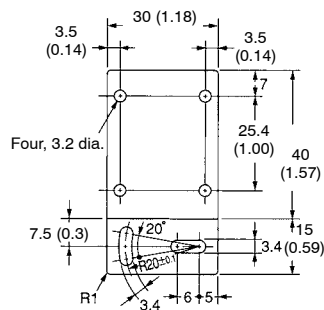
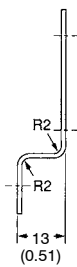

With Mounting Bracket
(E3Z-D62)

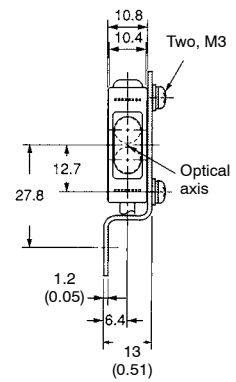

E39-L44

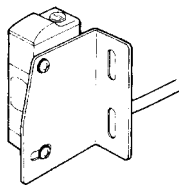

Material:
SUS304
stainless steel

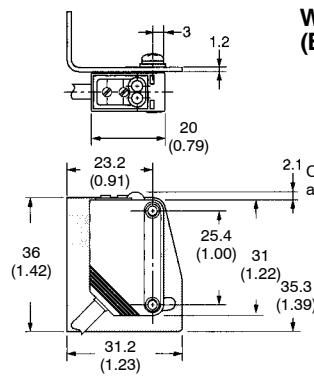
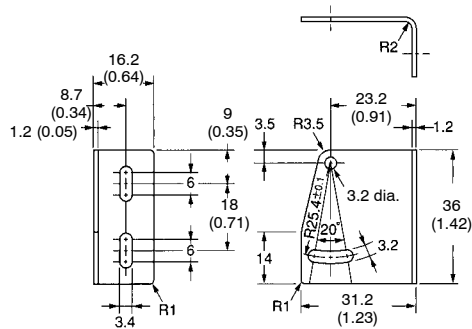

With Mounting Bracket
(E3Z-D62)

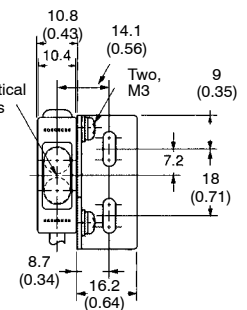

E39-L144

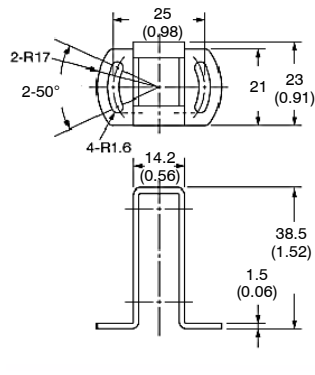

Material:
SUS304 stainless steel

**With Sensor
(Example: E3Z-L61)**

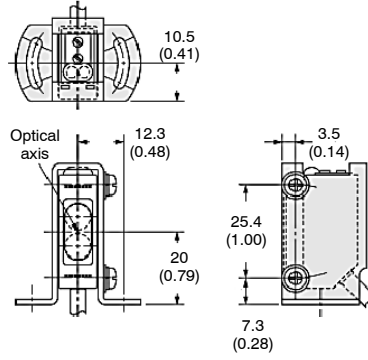

E39-L142

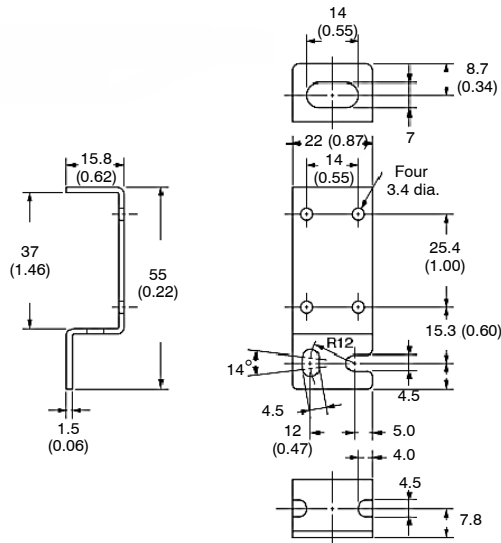

Material:
SUS304 stainless steel

**With Sensor
(Example: E3Z-L61)**

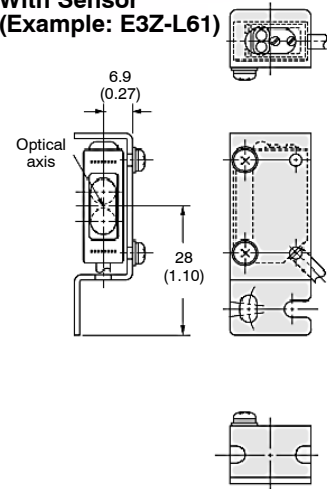

Unit: mm (inch)

E39-L93FH

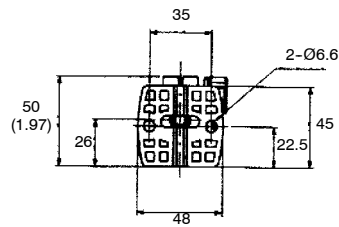
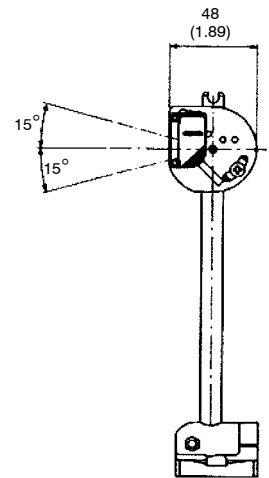
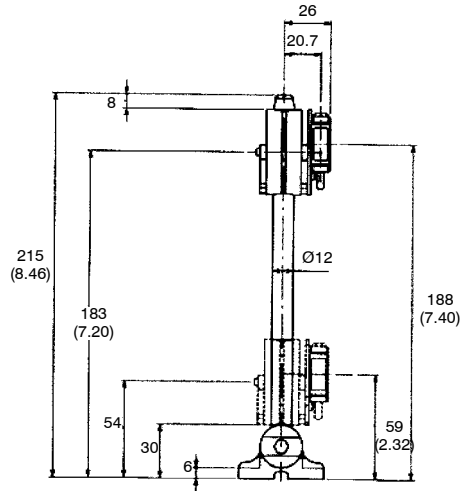
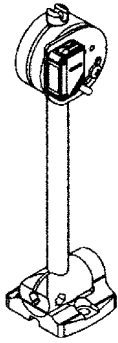

E39-L93FV

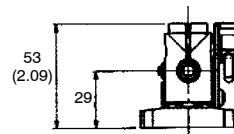
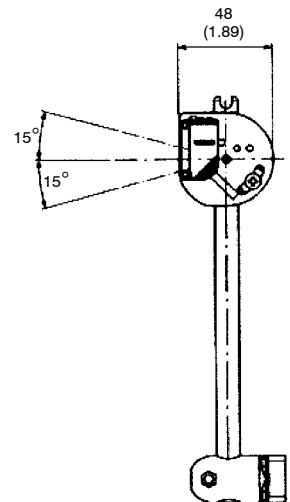
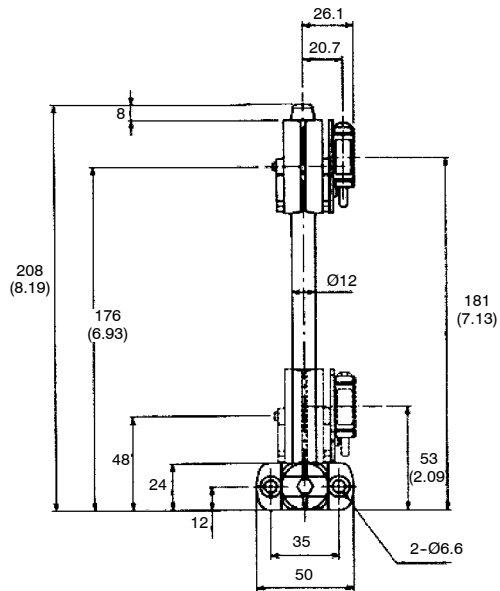
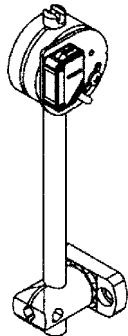

E39-L93H

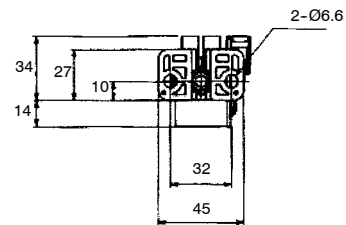
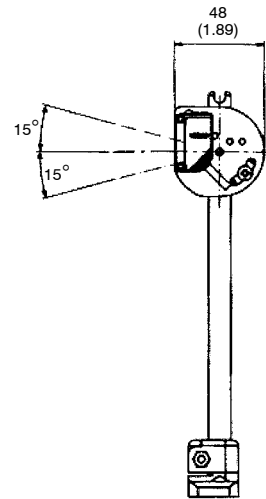
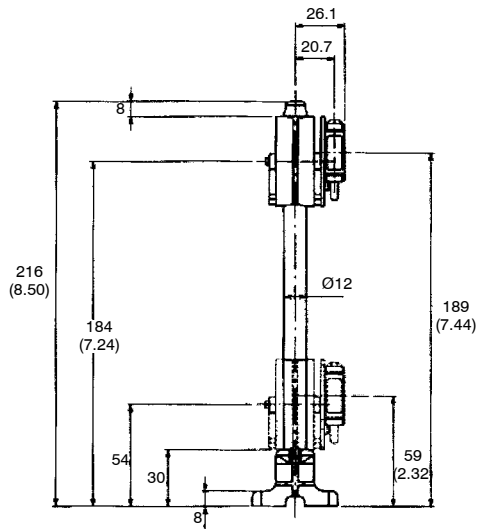

E39-L93V

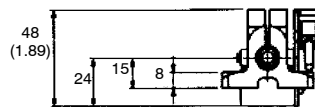
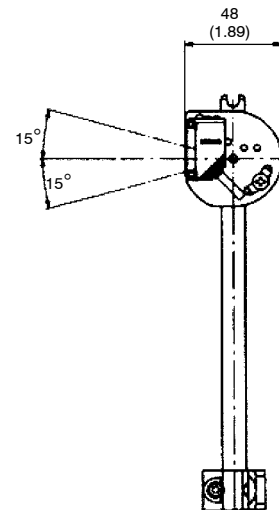
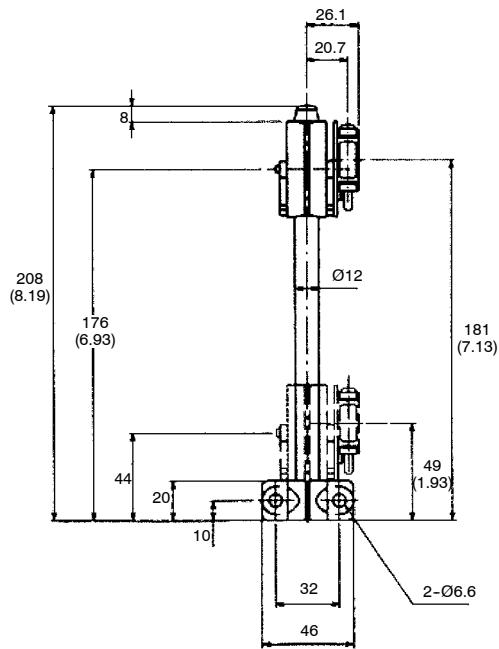
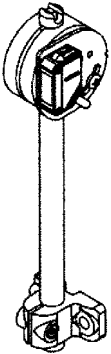

Unit: mm (inch)

E39-L93XY

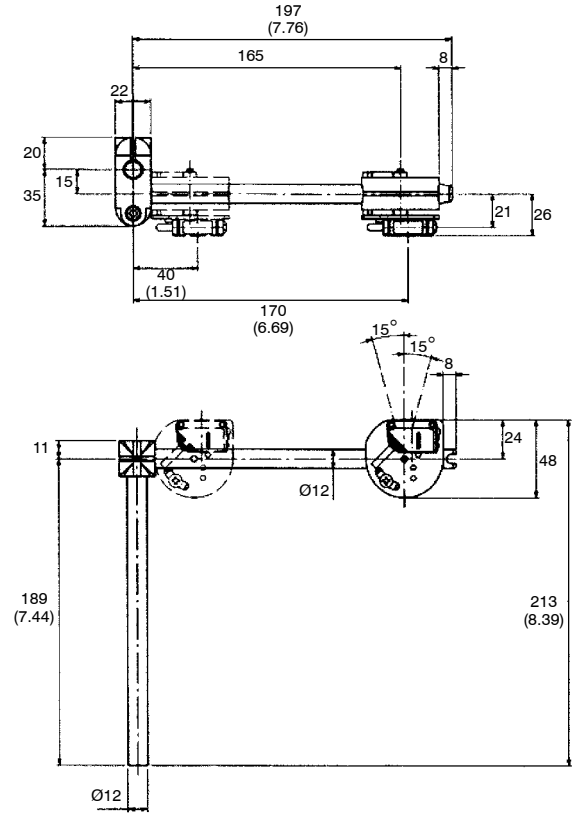
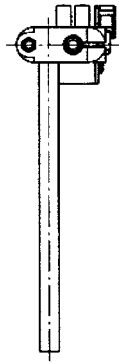
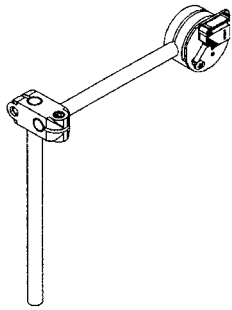

Note: The E39-L93XY consists of a vertical post, x-y joint, 2 nuts, 2 bolts and sensor mounting attachment. There is no base for the bottom of the vertical post.

E39-L98

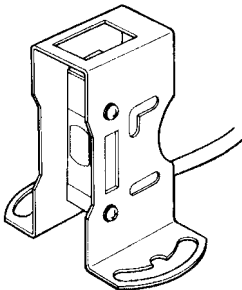

Material:
SUS304 stainless steel

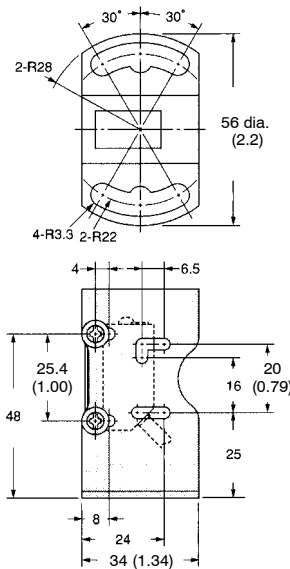
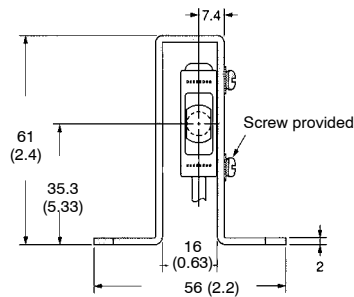

Mounting Holes

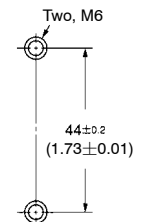

■ M8 Connector Cordsets (3-Pin)

Straight
Y96E-M833SD2
Y96E-M833SD5

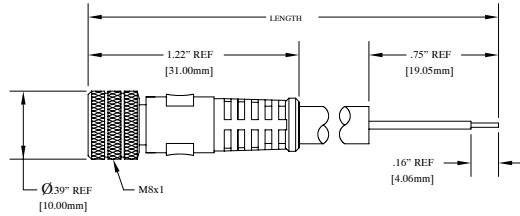
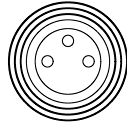

Right Angle
Y96E-M833RD2
Y96E-M833RD5

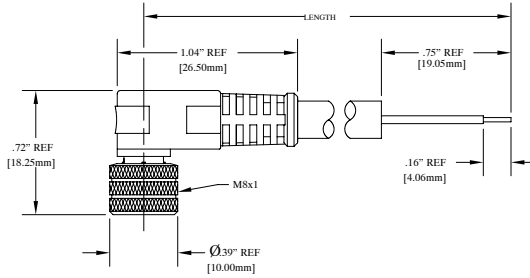
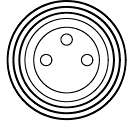

■ M8 Connector Cordsets (4-Pin)

Straight
XS3F-M421-402-A (L=2 m)
XS3F-M421-405-A (L=5 m)

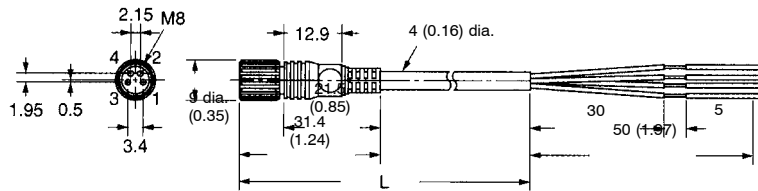

Right Angle
XS3F-M422-402-A (L=2 m)
XS3F-M422-405-A (L=5 m)

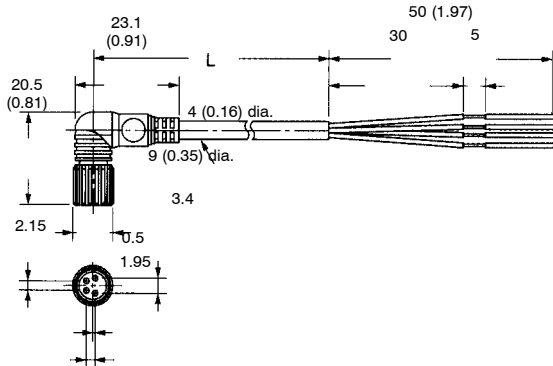

■ M12 Connector Cordsets (4-Pin)

Straight
Y96E-44SD2 (L=2 m)
Y96E-44SD5 (L=2 m)

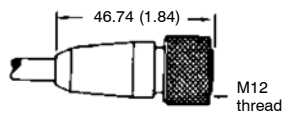
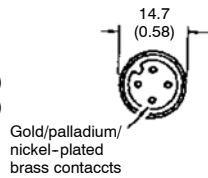

Gold/palladium/
nickel-plated
brass contacts

Right Angle
Y96E-44RD2 (L=2 m)
Y96E-44RD5 (L=2 m)

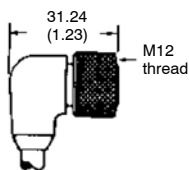
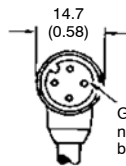

Gold/palladium/
nickel-plated
brass contacts

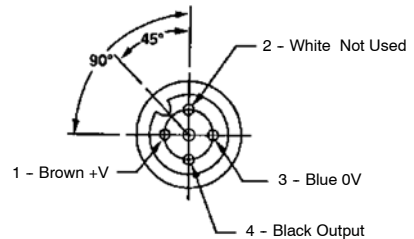

Precautions

To ensure safe sensor operation, please follow the following precautions:

■ Wiring

Power Supply Voltage

Make sure that the power supply to the Sensor is within the rated voltage range.

Load Short-circuiting

Do not short-circuit the load, or the Sensor may be damaged.

Polarity

Correct polarity wiring is required to prevent damage to the sensor.

Connection Without Load

Do not connect power supply to the Sensor with no load connected, or the internal elements may explode or burn.

■ Operating Environment

Do not use the Sensor in locations with explosive or flammable gas.

■ Settings

Power Reset Time

The Sensor is ready to operate 100 ms after the Sensor is turned ON. If the load and Sensor are connected to independent power supplies respectively, be sure to turn ON the Sensor before turning the load ON.

■ Connections

M8 Metal Connector

- Turn off power before disconnecting the sensor.
- Remove the connector cover before connecting or disconnecting the metal connector.
- Secure the connector cover by hand. Do not use any pliers, or the connector may be damaged.
- The proper tightening torque range is between 0.3 and 0.4 N • m. Be sure to tighten the connector securely in order to maintain the the specified degree of protection and to keep the connector from loosening due to vibration.

■ Mounting

Use M3 screws to mount the sensor and tighten each screw to a maximum torque of 0.53 N • m.

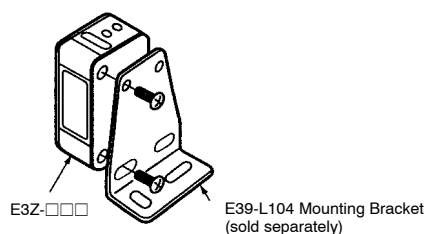

■ Adjustment

Slits for Through-beam Models (E39-S65A/B/C/D/E/F) Sold Separately

<p>Hook Upper indented mounting portion Protruding portion Lower indented portion Slit Sensor</p>	
<p>Mounting Method</p> <ol style="list-style-type: none"> 1. Hook the upper protruding portion of the Slit to the upper indented mounting portion of the Sensor and adjust the position of the Slit so that the Slit will be in parallel to the lens side of the Sensor. 2. Press the lower protruding portion of the Slit onto the indented mounting portion of the Sensor until the Slit snaps in. 	
<p>Mounting Condition</p>	<p>Side View Front View</p>
<p>Removal Method</p> <ol style="list-style-type: none"> 1. Press the upper portion of the Slit. 2. Disconnect the lower protruding portion of the Slit from the Sensor and remove the Slit. 	

Certain Terms and Conditions of Sale

- 1 **Offer/Acceptance.** These terms and conditions (these "Terms") are deemed part of all catalogs, manuals or other documents, whether electronic or in writing, relating to the sale of goods or services (collectively, the "Goods") by Omron Electronics LLC and its subsidiary companies ("Seller"). Seller hereby objects to any terms or conditions proposed in Buyer's purchase order or other documents which are inconsistent with, or in addition to, these Terms. Please contact your Omron representative to confirm any additional terms for sales from your Omron company.
- 2 **Prices.** All prices stated are current, subject to change without notice by Seller. Buyer agrees to pay the price in effect at time of shipment.
- 3 **Discounts.** Cash discounts, if any, will apply only on the net amount of invoices sent to Buyer after deducting transportation charges, taxes and duties, and will be allowed only if (i) the invoice is paid according to Seller's payment terms and (ii) Buyer has no past due amounts owing to Seller.
- 4 **Orders.** Seller will accept no order less than \$200 net billing.
- 5 **Governmental Approvals.** Buyer shall be responsible for, and shall bear all costs involved in, obtaining any government approvals required for the importation or sale of the Goods.
- 6 **Taxes.** All taxes, duties and other governmental charges (other than general real property and income taxes), including any interest or penalties thereon, imposed directly or indirectly on Seller or required to be collected directly or indirectly by Seller for the manufacture, production, sale, delivery, importation, consumption or use of the Goods sold hereunder (including customs duties and sales, excise, use, turnover and license taxes) shall be charged to and remitted by Buyer to Seller.
- 7 **Financial.** If the financial position of Buyer at any time becomes unsatisfactory to Seller, Seller reserves the right to stop shipments or require satisfactory security or payment in advance. If Buyer fails to make payment or otherwise comply with these Terms or any related agreement, Seller may (without liability and in addition to other remedies) cancel any unshipped portion of Goods sold hereunder and stop any Goods in transit until Buyer pays all amounts, including amounts payable hereunder, whether or not then due, which are owing to it by Buyer. Buyer shall in any event remain liable for all unpaid accounts.
- 8 **Cancellation; Etc.** Orders are not subject to rescheduling or cancellation unless Buyer indemnifies Seller fully against all costs or expenses arising in connection therewith.
- 9 **Force Majeure.** Seller shall not be liable for any delay or failure in delivery resulting from causes beyond its control, including earthquakes, fires, floods, strikes or other labor disputes, shortage of labor or materials, accidents to machinery, acts of sabotage, riots, delay in or lack of transportation or the requirements of any government authority.
- 10 **Shipping; Delivery.** Unless otherwise expressly agreed in writing by Seller:
 - a. Shipments shall be by a carrier selected by Seller;
 - b. Such carrier shall act as the agent of Buyer and delivery to such carrier shall constitute delivery to Buyer;
 - c. All sales and shipments of Goods shall be FOB shipping point (unless otherwise stated in writing by Seller), at which point title to and all risk of loss of the Goods shall pass from Seller to Buyer, provided that Seller shall retain a security interest in the Goods until the full purchase price is paid by Buyer;
 - d. Delivery and shipping dates are estimates only.
 - e. Seller will package Goods as it deems proper for protection against normal handling and extra charges apply to special conditions.
- 11 **Claims.** Any claim by Buyer against Seller for shortage or damage to the Goods occurring before delivery to the carrier must be presented in writing to Seller within 30 days of receipt of shipment and include the original transportation bill signed by the carrier noting that the carrier received the Goods from Seller in the condition claimed.
- 12 **Warranties.** (a) Exclusive Warranty. Seller's exclusive warranty is that the Goods will be free from defects in materials and workmanship for a period of twelve months from the date of sale by Seller (or such other period expressed in writing by Seller). Seller disclaims all other warranties, express or implied. (b) Limitations. SELLER MAKES NO WARRANTY OR REPRESENTATION, EXPRESS OR IMPLIED, ABOUT NON-INFRINGEMENT, MERCHANTABILITY OR FITNESS FOR A PARTICULAR PURPOSE OF THE GOODS. BUYER ACKNOWLEDGES THAT IT ALONE HAS DETERMINED THAT THE GOODS WILL SUITABLY MEET THE REQUIREMENTS OF THEIR INTENDED USE. Seller further disclaims all warranties and responsibility of any type for claims or expenses based on infringement by the Goods or otherwise of any intellectual property right. (c) Buyer Remedy. Seller's sole obligation hereunder shall be to replace (in the form originally shipped with Buyer responsible for labor charges for removal or replacement thereof) the non-complying Good or, at Seller's election, to repay or credit Buyer an amount equal to the purchase price of the Good; provided that in no event shall Seller be responsible for warranty, repair, indemnity or any other claims or expenses regarding the Goods unless Seller's analysis confirms that the Goods were properly handled, stored, installed and maintained and not subject to contamination, abuse, misuse or inappropriate modification. Return of any goods by Buyer must be approved in writing by Seller before shipment. Seller shall not be liable for the suitability or unsuitability or the results from the use of Goods in combination with any electrical or electronic components, circuits, system assemblies or any other materials or substances or environments. Any advice, recommendations or information given orally or in writing, are not to be construed as an amendment or addition to the above warranty.
- 13 **Damage Limits; Etc.** SELLER SHALL NOT BE LIABLE FOR SPECIAL, INDIRECT OR CONSEQUENTIAL DAMAGES, LOSS OF PROFITS OR PRODUCTION OR COMMERCIAL LOSS IN ANY WAY CONNECTED WITH THE GOODS, WHETHER SUCH CLAIM IS BASED IN CONTRACT, WARRANTY, NEGLIGENCE OR STRICT LIABILITY. Further, in no event shall liability of Seller exceed the individual price of the Good on which liability is asserted.
- 14 **Indemnities.** Buyer shall indemnify and hold harmless Seller, its affiliates and its employees from and against all liabilities, losses, claims, costs and expenses (including attorney's fees and expenses) related to any claim, investigation, litigation or proceeding (whether or not Seller is a party) which arises or is alleged to arise from Buyer's acts or omissions under these Terms or in any way with respect to the Goods. Without limiting the foregoing, Buyer (at its own expense) shall indemnify and hold harmless Seller and defend or settle any action brought against Seller to the extent that it is based on a claim that any Good made to Buyer specifications infringed intellectual property rights of another party.
- 15 **Property; Confidentiality.** The intellectual property embodied in the Goods is the exclusive property of Seller and its affiliates and Buyer shall not attempt to duplicate it in any way without the written permission of Seller. Notwithstanding any charges to Buyer for engineering or tooling, all engineering and tooling shall remain the exclusive property of Seller. All information and materials supplied by Seller to Buyer relating to the Goods are confidential and proprietary, and Buyer shall limit distribution thereof to its trusted employees and strictly prevent disclosure to any third party.
- 16 **Miscellaneous.** (a) Waiver. No failure or delay by Seller in exercising any right and no course of dealing between Buyer and Seller shall operate as a waiver of rights by Seller. (b) Assignment. Buyer may not assign its rights hereunder without Seller's written consent. (c) Amendment. These Terms constitute the entire agreement between Buyer and Seller relating to the Goods, and no provision may be changed or waived unless in writing signed by the parties. (d) Severability. If any provision hereof is rendered ineffective or invalid, such provision shall not invalidate any other provision. (e) Setoff. Buyer shall have no right to set off any amounts against the amount owing in respect of this invoice. (f) As used herein, "including" means "including without limitation".

Certain Precautions on Specifications and Use

1. **Suitability of Use.** Seller shall not be responsible for conformity with any standards, codes or regulations which apply to the combination of the Good in the Buyer's application or use of the Good. At Buyer's request, Seller will provide applicable third party certification documents identifying ratings and limitations of use which apply to the Good. This information by itself is not sufficient for a complete determination of the suitability of the Good in combination with the end product, machine, system, or other application or use. The following are some examples of applications for which particular attention must be given. This is not intended to be an exhaustive list of all possible uses of this Good, nor is it intended to imply that the uses listed may be suitable for this Good:
 - (i) Outdoor use, uses involving potential chemical contamination or electrical interference, or conditions or uses not described in this document.
 - (ii) Energy control systems, combustion systems, railroad systems, aviation systems, medical equipment, amusement machines, vehicles, safety equipment, and installations subject to separate industry or government regulations.
 - (iii) Systems, machines and equipment that could present a risk to life or property. Please know and observe all prohibitions of use applicable to this Good. NEVER USE THE PRODUCT FOR AN APPLICATION INVOLVING SERIOUS RISK TO LIFE OR PROPERTY WITHOUT ENSURING THAT THE SYSTEM AS A WHOLE HAS BEEN DESIGNED TO ADDRESS THE RISKS, AND THAT THE SELLER'S PRODUCT IS PROPERLY RATED AND INSTALLED FOR THE INTENDED USE WITHIN THE OVERALL EQUIPMENT OR SYSTEM.
2. **Programmable Products.** Seller shall not be responsible for the user's programming of a programmable Good, or any consequence thereof.
3. **Performance Data.** Performance data given in this catalog is provided as a guide for the user in determining suitability and does not constitute a warranty. It may represent the result of Seller's test conditions, and the user must correlate it to actual application requirements. Actual performance is subject to the Seller's Warranty and Limitations of Liability.
4. **Change in Specifications.** Product specifications and accessories may be changed at any time based on improvements and other reasons. It is our practice to change part numbers when published ratings or features are changed, or when significant construction changes are made. However, some specifications of the Good may be changed without any notice. When in doubt, special part numbers may be assigned to fix or establish key specifications for your application. Please consult with your Seller's representative at any time to confirm actual specifications of purchased Good.
5. **Errors and Omissions.** The information in this catalog has been carefully checked and is believed to be accurate; however, no responsibility is assumed for clerical, typographical or proofreading errors, or omissions.

Complete "terms and conditions of sale" for product purchase and use are on Omron's website at www.omron.com/oei - under the "About Us" tab in the Legal Matters section.

NOTE: DIMENSIONS SHOWN ARE IN MILLIMETERS. To convert millimeters to inches divide by 25.4.

OMRON[®]

OMRON ELECTRONICS LLC

One East Commerce Drive
Schaumburg, IL 60173

847-843-7900

For US technical support or other inquiries:

800-556-6766

OMRON CANADA, INC.

885 Milner Avenue
Toronto, Ontario M1B 5V8

416-286-6465

OMRON ON-LINE

Global - <http://www.omron.com>

USA - <http://www.omron.com/oei>

Canada - <http://www.omron.com.ca>